



The Product

Invisible Systems Boiler Control solution have been shown to provide energy savings of up to 40% in field

The Single Boiler Controller is a Bi-directional, multi-function web-based wireless real-time unit that enables a user to remotely control the boiler; operate heating and hot water systems separately; monitor energy usage and provide energy and temperature profiling.

The Boiler Control unit may be used in conjunction with Invisible Systems Energy Management solutions and could be a first step in improving energy efficiency and reducing Carbon output.

Features

- 868MHz RF
- Bidirectional communication
- Cloud based web application
- Provides Energy & Temperature profiling
- Provide automated reports audit trail and critical notifications via e-mail

Benefits

- Eliminates cabling required for an installation
- Allows the user to remotely control the boiler.
- The solution is operated from a single web interface enabling control of 1 or many facilities
- Offers information to change energy usage patterns
- Provides real-time alerts so immediate corrective action can be taken

Overview



Invisible Systems Ltd
 9 Beetham Road • Milnthorpe • Cumbria • LA7 7QL • ENGLAND
 T: +44 (0) 1539 722 520 • F: +44 (0) 1539 564 845
 E: info@invisible-systems.com • W: www.invisible-systems.com



Datasheet | Single Boiler Controller



Delivering information

Technical Information EC-01

Part number: 999-960-9605 EU only

Power Supply	Rated voltage: AC 230 V 50Hz EU Power consumption: 3.6W Fuse: 100mA
Measurement Performance	Temperature Range -20 to +85 DegC Temperature Accuracy $\pm 1\%$ of reading
Inputs	Digital inputs 3 x Digital temperature inputs Analogue 1 x 12VDC-230VAC
Outputs	Relay: 3 x 230VAC 8A (1xBoiler, Heating & Hot Water)
Mechanical	Enclosure Material : ABS Plastic Dimensions: 190Hx120Wx70D mm Weight: 720g Display: 16 characters x 2 Operating Ambient Temp: -20 to +85 Deg C Storage Temperature: -20 to +90 Deg C
RF	Frequency: Europe 868.950MHz Power: 50mW Range: Currently up to 1km
Data storage	Memory: 31 hour storage (52 records/hour)

Dimensions

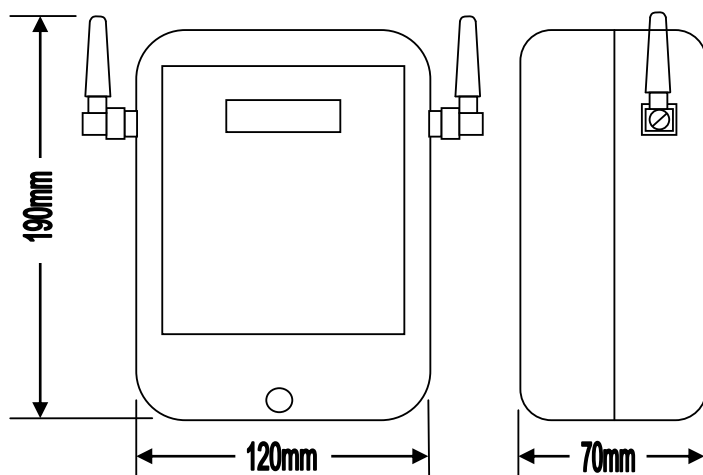

Invisible Systems Ltd

9 Beetham Road • Milnthorpe • Cumbria • LA7 7QL • ENGLAND

T: +44 (0) 1539 722 520 • F: +44 (0) 1539 564 845

E: info@invisible-systems.com • W: www.invisible-systems.com

